

Operating Instructions



Automatic sauna splash system Type Sauna Plus 8 Basic



Table of contents

1	About these instructions / general.....	4
1.1	Scope of applicability.....	4
1.2	Target group	4
1.3	Symbols used	4
1.4	Warranty.....	5
1.5	Further information	5
2	Safety.....	6
2.1	Intended use.....	6
2.2	Safety notices	6
2.2.1	Handling of chemicals, risks to humans and the environment	6
2.2.2	Protective measures and rules of conduct	7
3	Product description - scope of delivery.....	8
3.1	Scope of delivery/accessories.....	8
3.2	Product description	8
3.2.1	The dosing unit	9
3.2.2	Control unit.....	10
3.2.3	Piping and fittings	10
3.2.4	Oven shower head (series)	10
3.2.5	Wall bushing (option)	10
3.2.6	Extension (option)	10
3.2.7	Safety combination pipe separator/system separator	11
3.2.8	Connection set (option).....	11
3.3	Identification of the device/identification plate.....	11
3.4	Technical data.....	12
3.5	Transport/storage.....	12
4	Installation.....	13
4.1	Select the installation site	13
4.2	Installation instructions (assembly suggestion).....	13
4.3	Mechanical installation.....	14
4.4	Hydraulic installation	15
4.5	Electrical installation.....	16
5	Commissioning	17
5.1	Commissioning – remarks	17
5.2	Commissioning works	17
6	Operation/service.....	19
6.1	General	19
6.2	Control unit - software	19
6.2.1	Flow charts of the control unit	20
6.3	The menu.....	21
6.3.1	Operation modes.....	21
6.3.2	Pause time/Locking time	22
6.3.3	Water quantity	22
6.3.4	Fragrance quantity.....	22
6.3.5	Switch-on delay	22
6.3.6	Pump test	22
6.3.7	MV test	23
6.3.8	Pressure test.....	23
6.3.9	Splash test.....	23
6.3.10	Contrast	23
6.3.11	Language.....	23
6.3.12	Info.....	23
6.4	Replenish consumables	23
7	Maintenance, care, faults.....	24
7.1	Device maintenance	24
7.1.1	Check/change hose kit.....	24
7.1.2	Checking dosing valve.....	25

7.1.3	Clean oven shower head	25
7.1.4	Clean the dirt filter	25
7.2	Regular water check	25
7.3	Fault removal.....	26
8	Decommissioning – Storage – Disposal.....	28
8.1	General	28
8.2	Decommissioning	28
9	Documents	29
9.1	Declaration of conformity	29
9.2	Wiring Diagram	30
9.3	Commissioning protocol / instruction	31
9.4	Operation data sheet	32
9.5	Maintenance protocol.....	34
9.6	Spare parts list, wear parts list, list of consumables	35
10	Appendices.....	36

Imprint:

All rights reserved

© Copyright by WDT – Werner Dosiertechnik GmbH & Co KG

Edition: see footer

Reproduction of any kind and translation into other languages, even in excerpts, is only permitted with the express authorisation of the company WDT - Werner Dosiertechnik GmbH & Co. KG.

These operating instructions are an English translation of the original German version by the company WDT.

Responsible for the content:

Co. WDT - Werner Dosiertechnik GmbH & Co. KG

Hettlinger Str. 17

D-86637 Wertingen - Geratshofen

Phone: +49 (0) 82 72 / 9 86 97 – 0

Fax: +49 (0) 82 72 / 9 86 97 – 19

Email: info@werner-dosiertechnik.de



1 About these instructions / general

1.1 Scope of applicability

These instructions describe the functioning, installation, commissioning and operation of the SAUNA PLUS 8 Basic automatic sauna splash system along with the corresponding accessories.

The Operating Instructions must be read carefully prior to use or any maintenance work, and must be kept in close proximity to the device!

1.2 Target group

Only our authorised partners and persons who have been trained in the functioning of the device are permitted to work on the system, provided that they have read and understood these operating instructions.

Electrical connection work may only be carried out by appropriately trained specialists!

1.3 Symbols used

This document uses the following types of safety notices as well as general notices:



DANGER!

"DANGER" denotes a safety notice which, if disregarded, may lead to death or serious personal injury!



CAUTION!

"CAUTION" denotes a safety notice which, if disregarded, may lead to minor or moderate personal injury!



ESD SENSITIVE!

"ESD SENSITIVE" denotes electronic components that may be damaged by electrostatic discharges. The generally accepted safety precautions for ESD-sensitive devices must be observed when handling the devices!



ATTENTION!

"ATTENTION" denotes a safety notice which, if disregarded, may lead to material damage or malfunctions!



HIGHLY FLAMMABLE!

"HIGHLY FLAMMABLE" denotes substances with a low flashpoint, under 21°C.



NOTICE!

A notice denotes information which, if disregarded, may lead to malfunctions.



Tip!

A tip denotes information that may result in improvements in the operating process.

1.4 Warranty

All devices and systems of the Co. WDT are manufactured using state-of-the-art manufacturing methods and are subject to a comprehensive quality control. However, should there be a reason for complaint, any compensation claims shall be directed to the company WDT in accordance with the general terms and conditions of warranty (see below).

General terms and conditions of warranty

The company WDT assumes a 2-year warranty, starting with the commissioning, up to 27 months after delivery; subject to correct installation and commissioning with a completed and signed commissioning protocol.

Exempt from this are wear parts such as seals, hoses, diaphragms, dosing screws, electrodes, roller carriers and other parts that are subject to mechanical or chemical wear and tear. For these we assume a warranty of 1/2 year.

Our merchandise management programme requires an invoice for each delivery (including warranty services). When returning a defective component, upon review you will receive a corresponding credit, if applicable. We request a return within 14 days.

The costs for subsequent damage and for the processing of warranty claims are excluded.

There are no warranty claims for damage caused by frost, water and electrical overvoltage or by improper handling.



Tip!

In order to protect the warranty claims, please mail the completed commissioning protocol, along with the defective component, to the company WDT. Without the commissioning protocol, we reserve the right to assert a warranty regulation.



ATTENTION!

It is not permitted to make any modifications to the device. If this specification is not observed, the warranty obligation and product liability will expire!

1.5 Further information

Further information about special topics, e.g., description of the operating parameters, as well as additional support is available from your specialist dealer.

2 Safety

2.1 Intended use

The automatic sauna splash system type PLUS 8 Basic may only be used for the purposes indicated in Chapter 3.2, Product description! Also pay attention to the locally applicable regulations concerning accident prevention, occupational safety and drinking water protection!

2.2 Safety notices

Carefully read and pay attention to the operating instructions prior to installation and use of the device! Work on the device and changes in the settings may only be carried out by properly trained and instructed persons! It is of particular importance to comply with the rules for occupational safety and accident prevention and to wear protective clothing.

Pay attention to the warning notices on the device

	<p>Vor Öffnen des Gerätes Netzstecker ziehen. Before opening disconnect mains. Avant d'ouvrir l'appareil retirez la fichemâle. Antes de abrir el aparato sacar el enchufe.</p>	<p>Each time the fragrance is refilled, check the pump's dosing hose and renew it, if necessary. (see Operating Instructions)</p>
---	---	--

2.2.1 Handling of chemicals, risks to humans and the environment

Important information concerning the handling of chemicals and fragrances can be found in the safety data sheets provided by the fragrance manufacturers!

With the automatic sauna splash system, a fragrance is added to the water and dosed on the sauna heater. The fragrance concentration in the water is so low that there is no danger for people.



DANGER! IRRITATION!

The undiluted fragrances may cause irritation and allergic reactions.



HIGHLY FLAMMABLE!

The undiluted fragrances may be highly flammable. This may cause injuries and pose a danger to personnel and the environment. For this reason, the greatest possible care must be taken during all work!



CAUTION!

In high concentrations, the fragrances may be harmful to health!

In the event of an emergency when handling chemicals, you can contact the Emergency Poison Centre!

Emergency number:

Munich Emergency Poison Centre (or any other Poison Centre)

Phone: +49 89 19240

2.2.2 Protective measures and rules of conduct



CAUTION!

The automatic sauna splash system is supplied with water from the drinking water network.

The safety combination integrated in the device is a safety device in accordance with DIN EN 1717 (Germany and EU) for non-toxic liquids with free outlet, for the protection of the water network. For this purpose, the splash line from the device to the oven shower head must be laid in such a way that the line can drain itself (at a decline, without water trap, without non-return valve).

If the splash line cannot drain (e.g., installed at an incline, or water trap in the line), a system separation unit in accordance with DIN EN 1717 for non-toxic liquids without free outlet must be installed in the inlet of the automatic sauna splash system. In addition, a sauna splash connection set must be used. The connection set is available in the following lengths: 5 m, 10 m, 15 m, 20 m

Pay attention to the locally applicable regulations!



ATTENTION!

It is not permitted to make any modifications to the device. If this specification is not observed, the warranty obligation and product liability will expire!

3 Product description - scope of delivery

3.1 Scope of delivery/accessories

The automatic sauna splash system type Plus 8 Basic essentially consists of the following components:

- Micro-processor controller NT 35-R + HMI
- Peristaltic pump SA-Vi for fragrance concentrate
- Mounting plate with console for fragrance container
- Inlet with ball valve ½" IG
- Fine sieve 0.3 mm MS
- Safety combination/pipe aerator in accordance with DIN EN1717 for draining splash line
- 1 Solenoid valve VA ¼"
- Pressure monitoring
- Dosing pipe with dosing valve 3/8" VA
- Outflow 3/8" IG
- Splash shower head: Perforated pipe with interior thread 3/8"

The following optional accessories are available:

1. Wall bushing sauna VA for oven shower head: Item No.: 15214
2. Special versions of the wall bushing on request
3. Special versions of the splash shower head on request
4. Extension for oven shower head 3/8", various lengths
5. Sauna splash connection set, comprising:
 - a) PTFE hose 6x1 mm, (5 m Item no. 20101-1; 10 m Item no. 20101; 15 m Item no. 20101-2; 20 m Item no. 20101-3)
 - b) Hose connection automatic splash system 3/8" AG x6x1 mm
 - c) Hose connection wall bushing 3/8" IG x6x1 mm
 - d) 3/8" bracket IG AG
6. Button plate made of wood, incl. illuminated push button for operation in the cabin
7. System separation unit ½" for automatic sauna splash system (for non-draining splash line), Item no.: 24321
8. Hose connection Ms nickel-plated 3/8" IG for PTFE hose 6x1 mm, Item no.: 19282

3.2 Product description

The automatic sauna splash system Sauna Plus 8 Basic is a dosing system for a fully automated splash on the sauna heater. During the splash, a fragrance is automatically dosed into the splash water.

The pause time, the quantity of water (= splash quantity) and the fragrance quantity (= scent intensity) can be set individually via the control unit.

The device can be operated via an internal cyclic programme or via an optional push button. The splash system can also be activated externally via the "button input".

Function

For a splash, the solenoid valve (4) opens and the splash water flows to the sauna heater. The water is backed up at the washer installed downstream of the pressure switch (5), leading to a pressure build-up. Once the pressure rises above 1.2 barg, fragrance dosing is released. The dosing pump (10) doses the set fragrance quantity from the fragrance container (16) via the dosing valve (7) into the water that is flowing toward the sauna heater. The splash occurs. At the end of the splash, the solenoid valve closes again. The pressure switch monitors the pressure reduction in the splash line, which must take place within 3 seconds after the solenoid valve closes.

If the pressure of 1.2 barg is not reached, or the pressure drops during splash, the message "Water pressure fault" appears, a safety shutdown for the fragrance takes place and the solenoid valve remains open (see Chapter 7.3, Fault removal). This ensures that the fragrance concentrate can only be dosed when the

necessary water pressure is present in the device. This is important because no undiluted fragrance concentrate must get onto the sauna heater. This can be flammable!

The built-in safety combination (3) in accordance with DIN EN 1717 (non-return valve + aerator) additionally ensures that no splash water can be sucked back into the piping network in the event of a pressure drop. The safety combination (3) is preceded by a dirt filter (8) and a ½" shut-off ball valve (9).



ATTENTION!

To avoid dosing on the cold heater, the automatic sauna splash system must be interlocked with the sauna control unit on site! If the internal switch-on delay (adjustable) is activated, it prevents the first splash after the mains connection. If needed, this switch-on delay can be deactivated.

Overview automatic sauna splash system dosing type: Sauna Plus 8 Basic

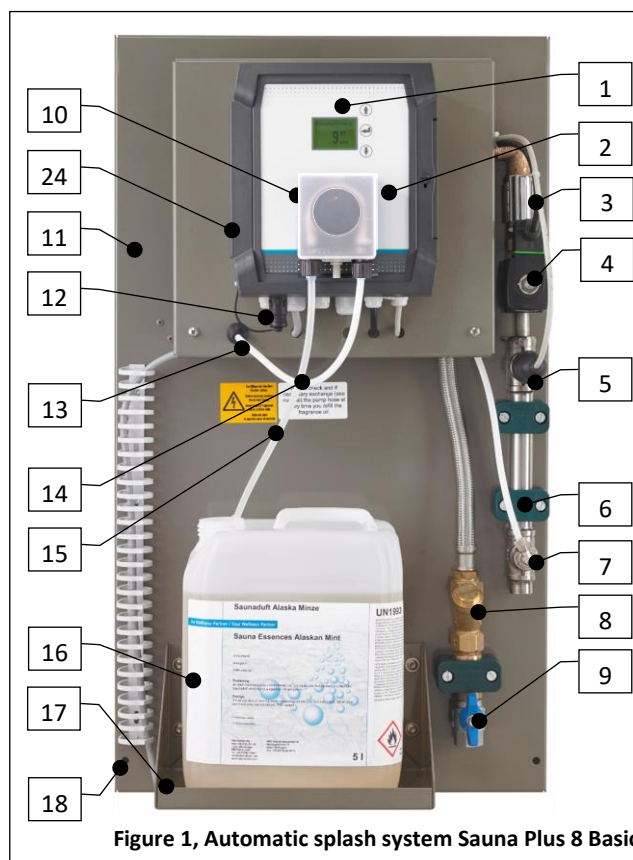

Figure 1, Automatic splash system Sauna Plus 8 Basic

Key

1. Display with 3 operating buttons
 2. Control housing
 3. Safety combination in accordance with DIN EN 1717(non-return valve + aerator)
 4. Solenoid valve
 5. Pressure switch
 6. Pipe bracket
 7. Fragrance dosing valve
 8. Dirt filter
 9. Shut-off ball valve
 10. Peristaltic pump
 11. Mounting plate
 12. Power socket for push button
 13. Fragrance pressure line
 14. Fragrance suction line
 15. Warning notices
 16. Fragrance container
 17. Console for fragrance container
 18. Earth connection
24. Main switch (covered, see Figure 17, Control unit with display)

3.2.1 The dosing unit

Fragrance dosing is performed using a peristaltic pump, which can also reliably transport the smallest dosing quantities, even when air or gas bubbles are trapped in the suction line. The rotating rollers press the dosing hose against the wall, which pushes the liquid in the hose out in front of the rollers while simultaneously sucking more liquid in behind them. It is exceptionally reliable and also very easy to operate.

Fragrance concentrations may be exceptionally aggressive. The dosing hose used is resistant to most commercially available concentrates.

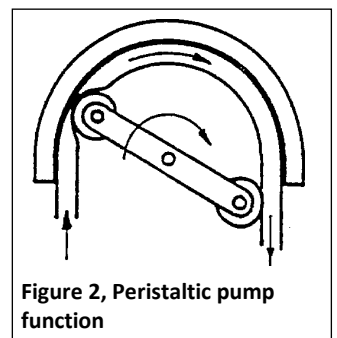

Figure 2, Peristaltic pump function

The installation of a combined spring-loaded non-return and dosing valve reliably prevents water from being pushed back or the dosing line from draining. The valve body is completely made of stainless steel, hose connection 4x1 mm (angular shape) - thread 3/8" AG. The opening pressure is 0.69 barg.

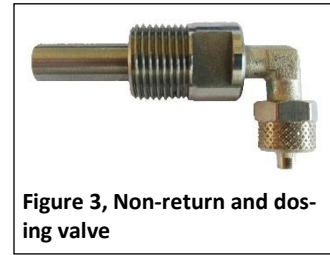

Figure 3, Non-return and dosing valve



ATTENTION!

The composition of fragrances varies. This may reduce the service life of the hose in the fragrance pumps. The fragrance pump must therefore be checked regularly in accordance with the maintenance schedule, and each time the fragrance is refilled.

3.2.2 Control unit

The control unit consists of a housing with protection class IP44. The electronic components are installed in the housing. The operating parameters can be set at the control unit.

3.2.3 Piping and fittings

The piping of the automatic sauna splash system consists of a shut-off ball valve (9), a dirt filter (8) and a safety combination (3), which complies with the DIN EN 1717 regulation when the splash line is draining, so that no water can be sucked back into the water supply. Furthermore, the piping consists of a shut-off solenoid valve (4), the splash pipe with integrated washer, a pressure switch (5) for pressure monitoring and the dosing valve.

3.2.4 Oven shower head (series)

The standard scope of delivery includes a oven shower head consisting of a stainless steel pipe d 18x200 mm with drill holes that distribute the water over the heater stones. The oven shower head has a 3/8" interior thread connection.



Figure 4, Oven shower head (series)

3.2.5 Wall bushing (option)

For the installation and secure fastening of the oven shower head, we offer different wall bushings with 3/8" AG thread connection made of stainless steel; see Chapter 3.1 *Scope of delivery/accessories*.

Standard dimensions:

Length before the flange: 190 mm

Length behind the flange: 90 mm

Flange diameter: 60 mm



Figure 5, Example of a wall bushing for the oven shower head

Other dimensions on request, special versions are possible

3.2.6 Extension (option)

For the installation and secure fastening of the oven shower head, we offer different extensions with 3/8" x120mm IG-AG thread connection made of stainless steel; see Chapter 3.1 *Scope of delivery/accessories*.



Figure 6, Extension

3.2.7 Safety combination pipe separator/system separator

Safety combination (3) in accordance with DIN EN 1717 (non-return valve + aerator)



Figure 7, Safety combination

3.2.8 Connection set (option)

The sauna splash connection set for connecting the automatic sauna splash system to the wall bushing.

The connection set is available with various hose lengths:

- 5 m → Item no. 20101-1
- 10 m → Item no. 20101
- 15 m → Item no. 20101-2
- 20 m → Item no. 20101-3



Figure 8, Connection set

3.3 Identification of the device/identification plate

Enter the data from your device's identification plate here.

Field 1: Enter serial number

Field 2: Enter date of manufacturing

Typ: Sauna Plus 8 Basic
Art.: 25980 Serien Nr.: <input type="text"/>
230V - 1~ 50Hz - P: 50 W
Herstellung <input type="text"/>
WDT - Werner Dosiertechnik GmbH & Co KG
Hettlinger Str. 17
D-86637-Wertingen

Figure 9, Identification plate

3.4 Technical data

	Sauna Plus 8 Basic
Dimensions and weights:	
External dimensions	0.70x0.40x0.23 m; HxWxD
Space requirement	0.90x0.50x0.30 m; HxWxD
Space requirement, including operation and maintenance	2.00x0.60x1.00 m; HxWxD
Empty weight/operating weight	10 kg/15 kg
Connection data	
Water inlet	1/2" IG (up to 2.5 l/min)
Splash line outflow	3/8" IG
Oven shower head connection	3/8" IG
Electrical connection	230 VAC/50 Hz, 50 W, safety plug
Fuse F500	2A slow, D8, 3x8
Nominal pressure/operating pressure (flow pressure)	1.5-6 barg/1.5-6 barg
Operating data:	
Splash water at 4 barg flow pressure	max. 1200 ml per splash at 100%
Fragrance	max. 24 ml per splash at 100%
Cycle time/pause time	1-90 minutes
Fragrance pump	24 VDC
Solenoid valves	1/4" IG, 230 VAC
Control unit for automatic splash system	230V AC
Medium temperature	5-30°C
Ambient temperature technical room	5-30°C
Humidity technical room	max. 70%
Ventilation (in and out)	Recommended in the technical room
Software version	V 2.1
Hardware version	NT 35-R + HMI

3.5 Transport/storage

Please check the device immediately upon receipt for potential transport damage.



ATTENTION!

The device may be damaged by frost or high temperatures. Avoid exposure to frost during transport and storage! Do not store systems and devices next to objects with strong heat emission or in direct sunlight. The device may only be transported and stored in its original packaging. Please ensure careful handling.

For transport and storage purposes, the roller carrier of the dosing pump is not mounted. This prevents the hose from becoming deformed.

Storage of fragrances/chemicals



DANGER!

The safety data sheets provided by the fragrance manufacturer must be observed during storage!

These are some of the points that must be observed:

- The fragrances must only be stored in the appropriately identified original plastic containers.
- Larger quantities of fragrances must be stored in a separate storage room.
- The ambient temperature must not exceed 20°C.

See also *Chapter 2.2.1 Handling of chemicals*.



ATTENTION!

Pay attention to the locally applicable regulations for handling chemicals!

4 Installation

The tasks described here must only be performed by appropriately qualified personnel from a specialist company.

4.1 Select the installation site

The installation site must have the following properties:

1. The installation site must be frost-proof.
2. The system must be protected from direct sunlight.
3. An electrical power connection with a safety contact is required.
4. It is recommended that the storage space be well aerated and ventilated.
5. A waste water connection must be available. (Only necessary for version with system separation)

4.2 Installation instructions (assembly suggestion)

The automatic sauna splash system is installed on a wall in the technical room. The line to the sauna heater should be as short as possible. Pay attention to the space required for operation and maintenance of the device, see *Chapter 3.4 Technical data*.

- Warning and information notices must be installed in compliance with locally applicable accident prevention regulations at the locations provided!

Installation plan, draining splash line

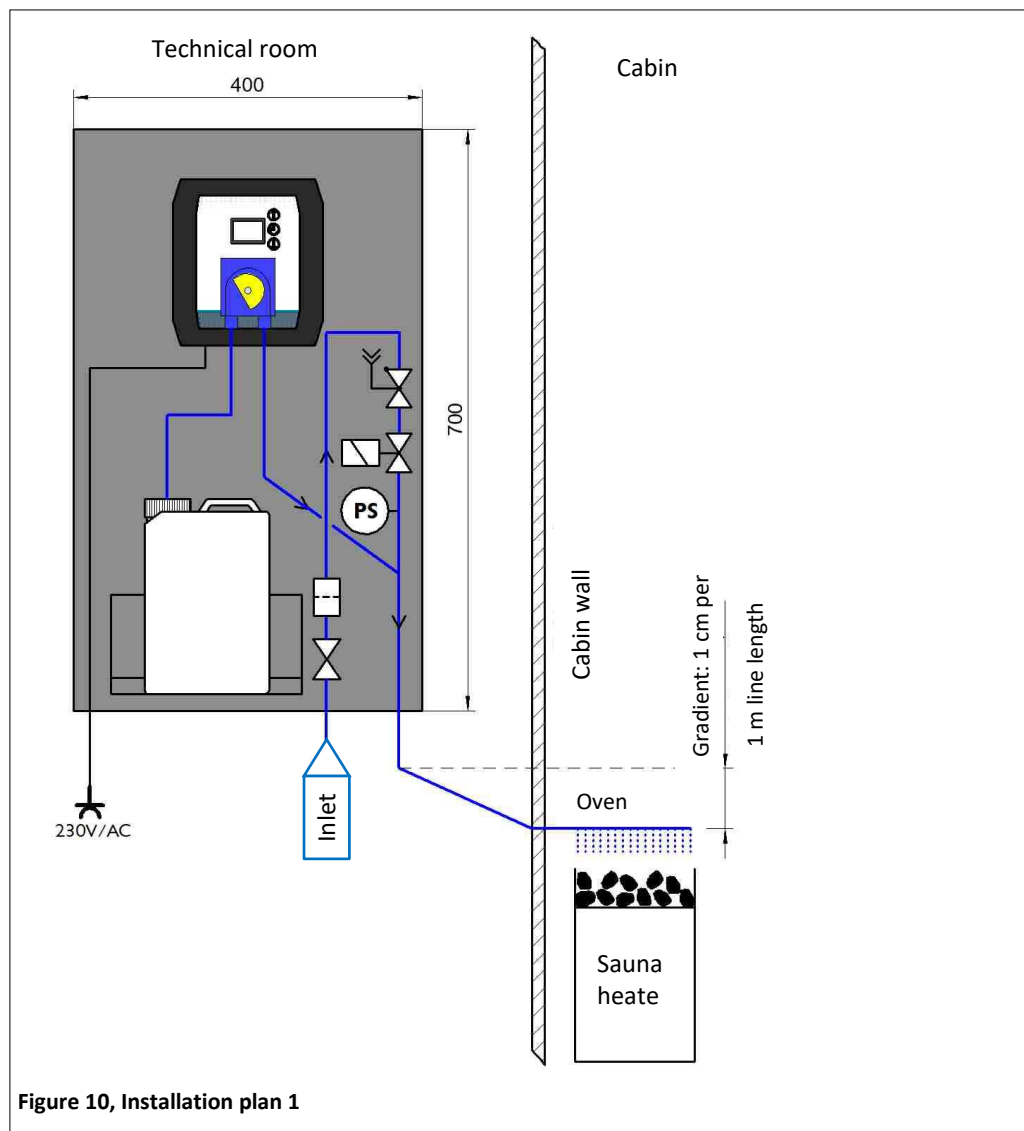

Installation plan, non-draining splash line

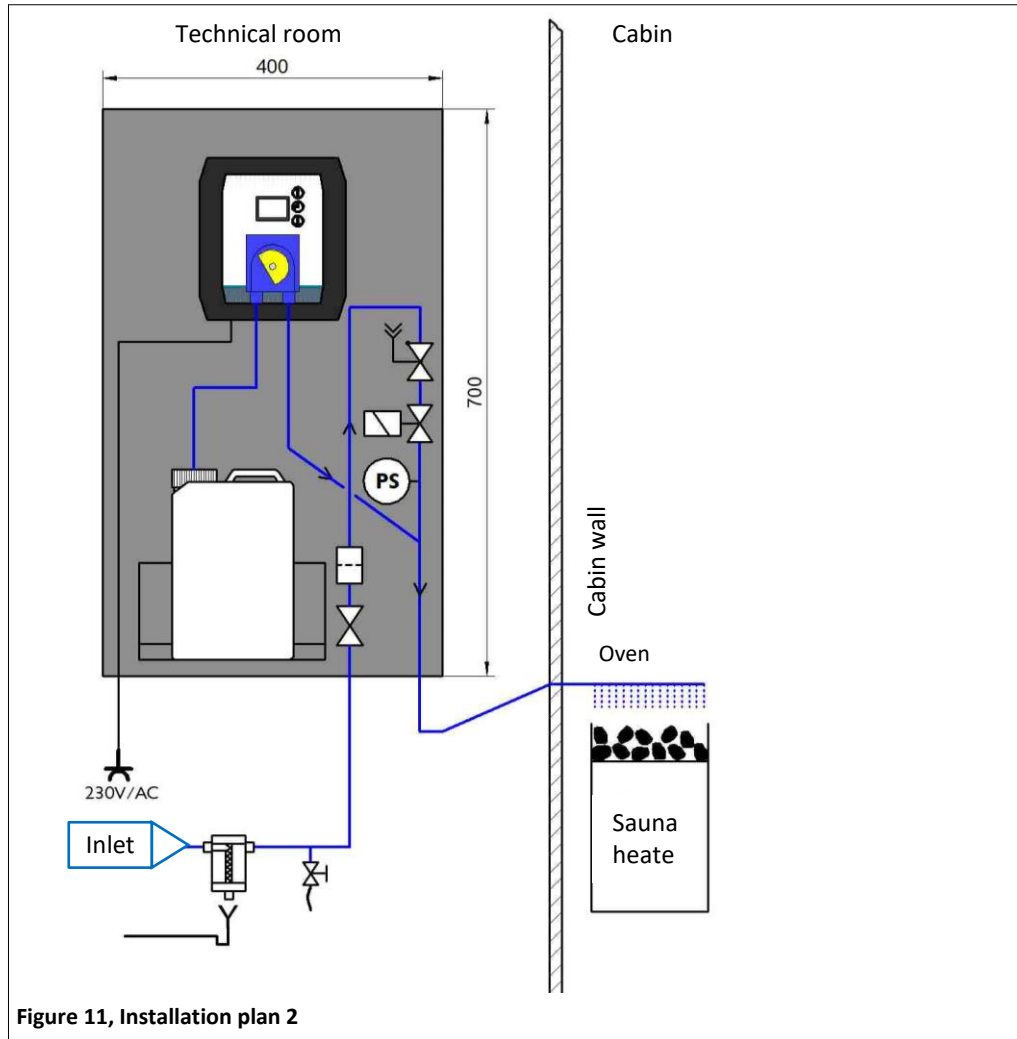

4.3 Mechanical installation

Installing dosing device

With the exception of the roller carrier, the SAUNA PLUS 8 Basic dosing device is delivered ready for operation. It should be installed in an easily accessible location.

The splash line to the oven shower head must be installed with a gradient of at least 1 cm per 1 m of line length! The oven shower head, in turn, must be mounted approx. 10-15 cm above the sauna heater.

Securely attach the mounting plate on the wall with 4 screws and ensure easy accessibility.

Install wall bushing for oven shower head (option)



Tipp

Tip!

For the installation and secure fastening of the oven shower head, a wall bushing with two 3/8" AG thread connections made of stainless steel is available (see Chapter 3.2.5).

Drill a hole of approx. 18 mm in the sauna wall approx. 10-15 cm above the heater, then insert the wall bracket with the rosette from the inside. The rosette is attached to the sauna wall with the V4A screws supplied.



Hinweis

NOTICE! Underbench heaters

If the automatic sauna splash system is connected to an underbench heater, make sure that it is professionally connected to the connection pipe prepared on the heater side! Please pay attention to any specifications by the heater manufacturer.

4.4 Hydraulic installation



ATTENTION!

Rinse the supply line to the automatic splash system and then connect the automatic splash system's inlet to the supply line.

Splash line to the oven shower head/wall bushing

There are 2 different variants for connecting the splash line to the oven shower head:

Variant a: The splash line is installed in such a way that it can drain completely.

Variant b: The splash line is installed in such a way that it cannot drain completely (e.g., water trap, installed at an incline).

For variant a) The line can drain

Use a pipe with a maximum interior diameter of 13 mm.



ATTENTION!

If the splash line drains on its own, the safety combination installed as a standard according to DIN EN 1717 (for Germany and EU) is sufficient for non-toxic liquids with free outlet.

Connection of the splash line 3/8" interior thread to the wall bushing (option) 3/8" AG. Screw the oven shower head hand-tight onto the wall bushing. Only use Teflon tape for sealing to keep the shower head cleaning as simple as possible.

For variant b) The line cannot drain



DANGER!

If the splash line cannot drain (e.g., installed at an incline, or water trap in the line), an additional system separation unit in accordance with DIN EN 1717 (for Germany and the EU) for non-toxic liquids without free outlet must be installed in the inlet of the automatic sauna splash system. This prevents any fragrance from being sucked back into the drinking water line! (see Chapter 3.1 Scope of delivery/accessories)

Use a pipe or hose with a maximum interior diameter of 6 mm.

Connection of the splash line 3/8" interior thread to the wall bushing (option) 3/8" AG. Screw the oven shower head hand-tight onto the wall bushing. Only use Teflon tape for sealing to keep the shower head cleaning as simple as possible.



ATTENTION!

For non-draining splash line only use the WDT connection set!

The optional sauna splash connection set from WDT is used to connect the automatic sauna splash system to the wall bushing.

4.5 Electrical installation



DANGER DUE TO ELECTRICAL VOLTAGE!

Electrical installation must only be carried out by appropriately qualified personnel! Before any electrical work is carried out, the automatic sauna splash system must be switched off and secured against being reactivated!

Connect the earth connection (Pos 18) to the on-site earthing cable.

Open/close the housing

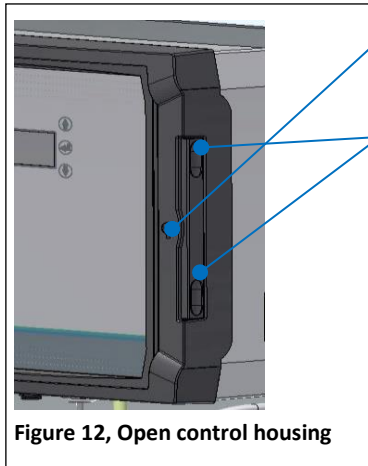

Figure 12, Open control housing

Unlock the locking knob with a screwdriver

Press down on both recessed grips until the housing snaps open. Rotate the cover to the side.

To close the housing, follow the procedure in reverse sequence



ATTENTION!

Connect the automatic sauna splash system to the sauna control unit so that the automatic splash system is only supplied with power when the sauna heater is turned on. If fragrance collects on the cold sauna heater, the fragrance may ignite during heating.

5 Commissioning

5.1 Commissioning – remarks

The tasks described here must only be performed by appropriately qualified personnel from a specialist company. Alternatively, the work can be carried out by persons who have read and understood the entire Operating Instructions. Prior to commissioning, the installed systems must be checked for proper installation and leaks.

Please use the commissioning protocol from *Chapter 9.3* for commissioning.

The device comes loaded with ex works settings. During the commissioning, adjust the control parameters to the desired operating mode and enter them in the operation data sheet in *Chapter 9.4*.

5.2 Commissioning works

Filling and starting the automatic sauna splash system

1. Please ensure that the device has been correctly installed and connected.
2. Unscrew the cover of the fragrance delivery container and drill a hole with a diameter of 7 mm in the cover. Screw the cover back on and place the delivery container on the console of the automatic sauna splash system.
3. Secure the fragrance container with the Velcro tape.



CAUTION!

The console is designed for loads up to 5 kg. If this load is exceeded, place the fragrance containers on a separate shelf.

Most fragrances are highly flammable!

4. Connect the fragrance container to the fragrance pump. Push the suction hose so far into the container that the end of the suction hose comes into contact with the container base.

Insert the roller carrier at the fragrance pump

1. Remove the clipped-in, transparent pump cover and the safety disc (32). Pull the hose bracket (33) out of the guide in the housing. (During initial commissioning, the parts are not installed, but can be found in the accessory bag)

Key

31. Transparent pump cover (not shown)
32. Safety disc
33. Hose bracket with dosing hose made of Viton (hose kit)
34. Roller carrier (not visible)
35. Pump casing
41. Suction connection
42. Pressure connection

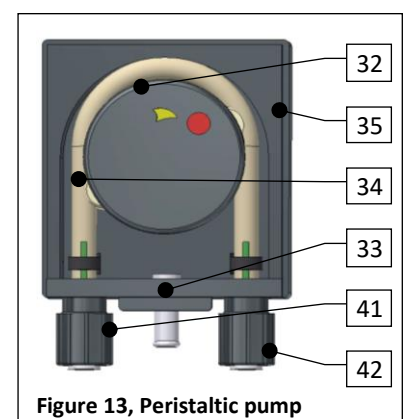
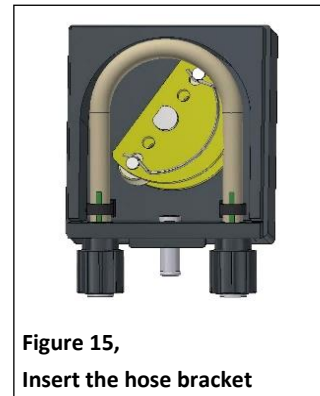

Figure 13, Peristaltic pump

2. Push the yellow roller carrier onto the axle.



3. Insert the hose bracket into the housing's guides until it firmly snaps into place.



4. Turn the roller carrier clockwise while carefully pushing the hose into the housing until the entire hose is contained in the housing.

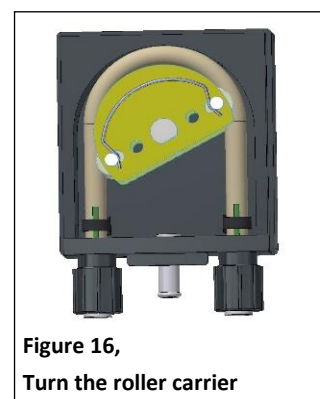

Now replace the safety disc and the transparent pump cover. This completes the installation of the roller carrier.

For dismantling the roller carrier and the hose bracket, please proceed in the reverse sequence.

Plug the safety plug in a corresponding power socket and turn on the device at the main switch.

If the switch-on delay is activated, the first splash can be delayed between 0-120 minutes after switching on the voltage. This prevents the splash from being made on the cold sauna heater. After that, the splashes take place according to the set cycle or after a push button prompt.

Ensure that all installation tasks have been completed. Observe the sequence of the commissioning works.

The device is now ready for operation.

6 Operation/service

6.1 General

The tasks described here may only be carried out by appropriately trained and instructed personnel. Alternatively, the work may be done by operating personnel who have read and understood the entire operating instructions.

Once all preparations for the commissioning have been completed, the operation can be started. Turn on the device at the main switch (unless this has already been done).

6.2 Control unit - software

The automatic sauna splash system is operated via the control unit on the front of the device. Pressing any key switches the display to the main menu.



ATTENTION!

A splash cycle only starts when the display shows the start display. If the sub-menus are displayed, the splash cycle is blocked.

Use the 3 operating buttons to navigate in the menu.

The control unit's main menu is simply structured and easy to operate. It consists of an operating level with the following menu items:

- | | |
|--|------------------|
| 1. Pause time (with cyclic operation)/locking time (with button operation) | 7. MV test |
| 2. Water quantity | 8. Pressure test |
| 3. Fragrance quantity | 9. Splash test |
| 4. Operation mode | 10. Contrast |
| 5. Switch-on delay | 11. Language |
| 6. Pump test | 12. Info |

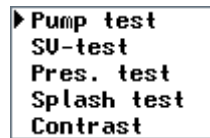
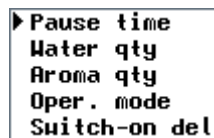

A start button can be plugged in at the control housing.

Overview control unit

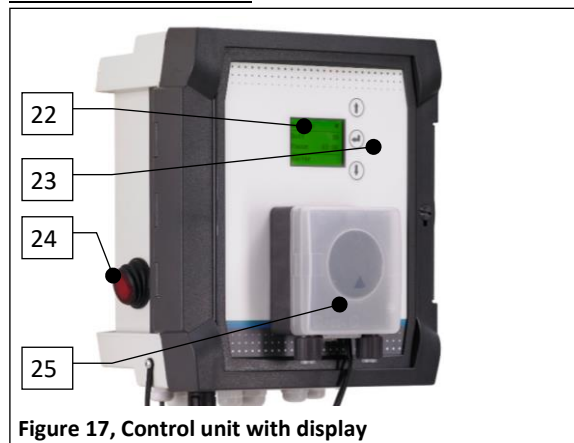

Figure 17, Control unit with display

Key

- 22. Display
- 23. 3 operating buttons for operation
- 24. Main switch
- 25. Dosing pump

Operating the display

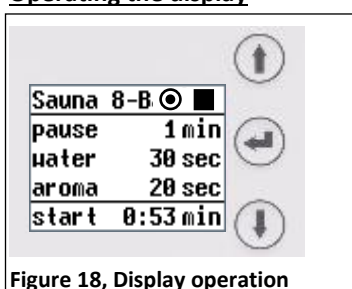

Figure 18, Display operation

The device is operated via 3 operating buttons next to the display.

Use the **arrow keys** to navigate **up or down** or to set numerical values. Use the **Enter key** to navigate to the selected **sub-menu** and **back**.

6.2.1 Flow charts of the control unit

Example with start by means of Cyclic operation operation mode

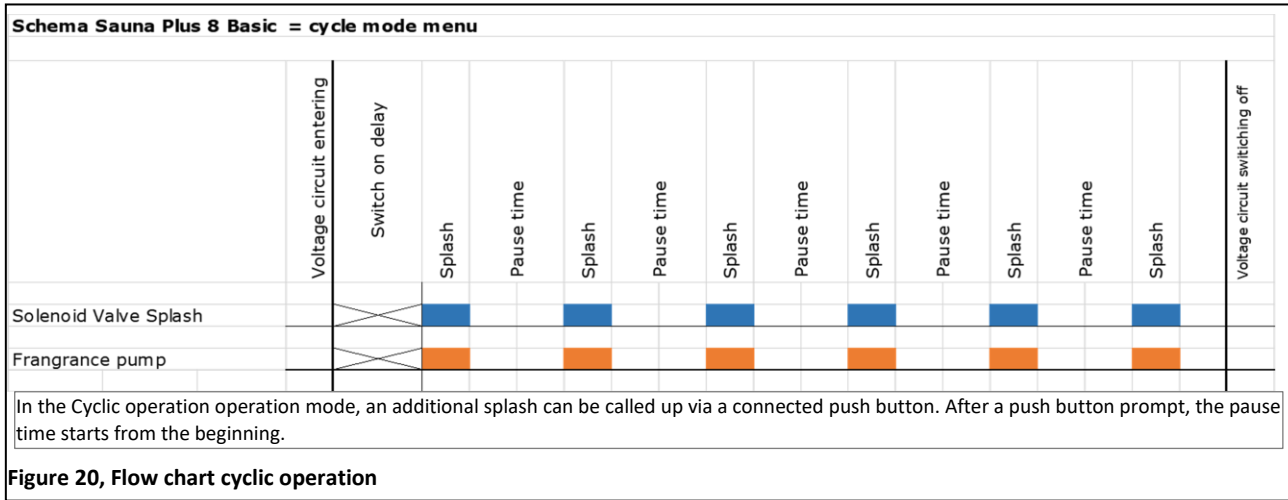

Example with start by means of Button operation operation mode delivery state SL 6/1+3

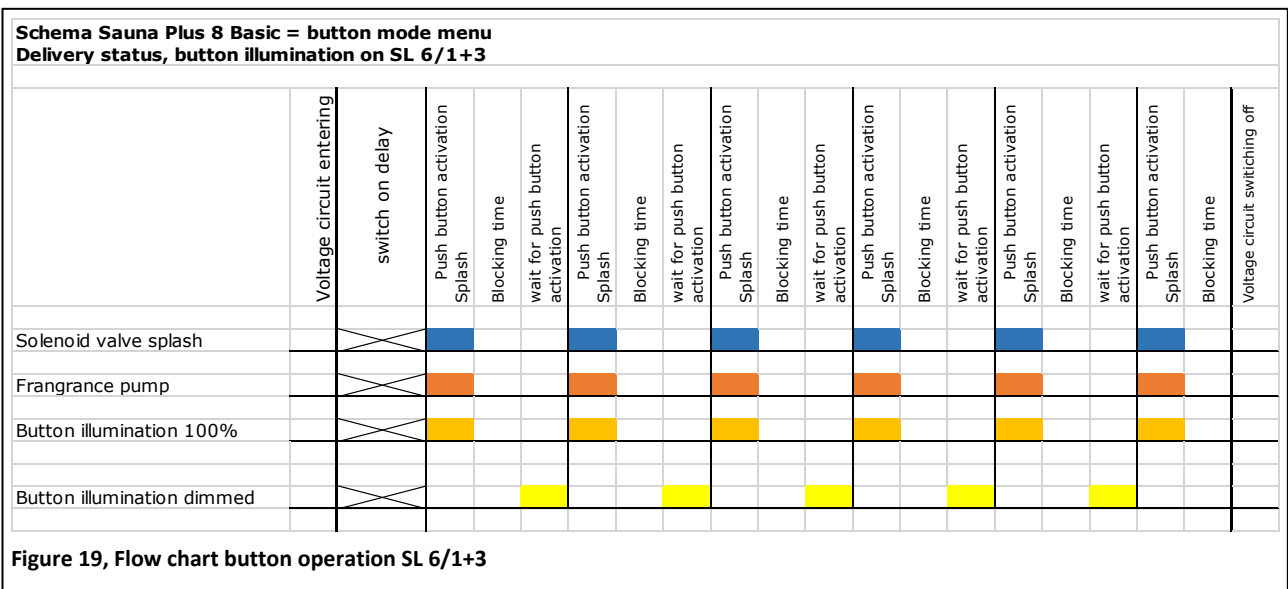

Example with start by means of Button operation operation mode option SL 6/4+6

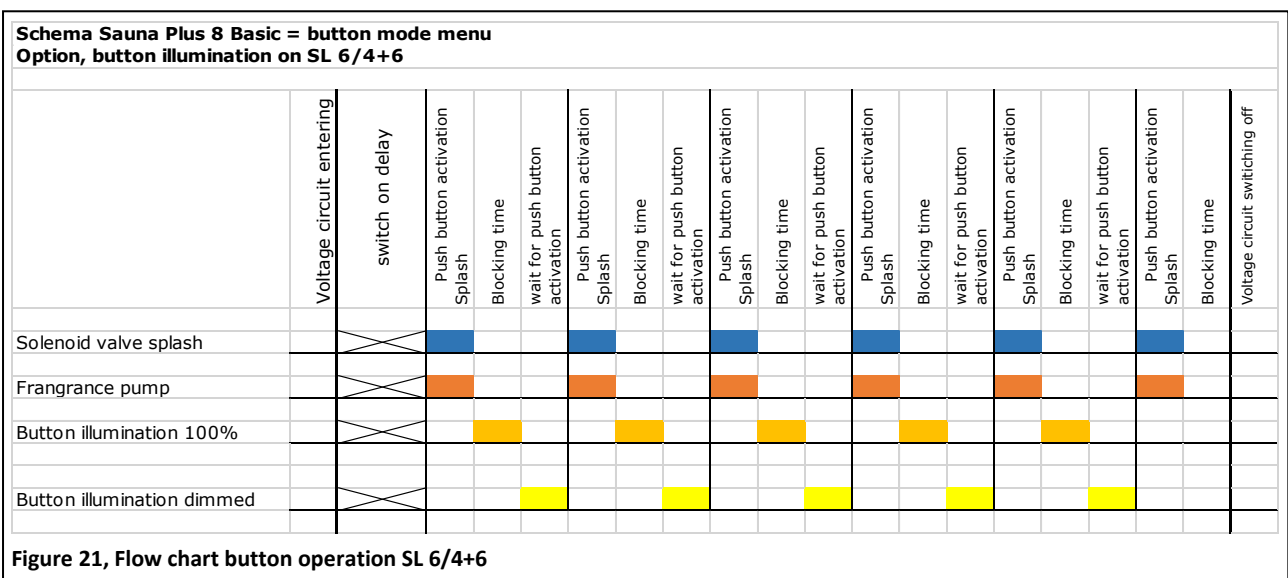

6.3 The menu

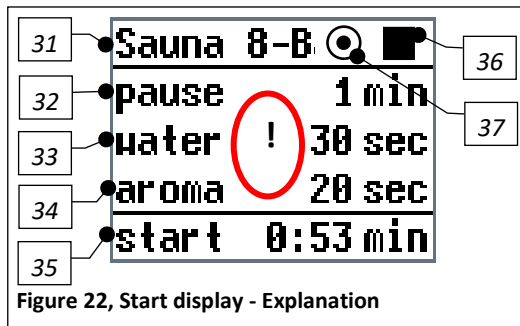

Start display key

- 31. Device name
- 32. Set pause time or locking time, respectively
- 33. Set time for water dosing
- 34. Set time for fragrance dosing
- 35. Time until the start of the next splash or until the end of the locking time, respectively.
- 36. Display for the operating contact
- 37. Display for the push button contact

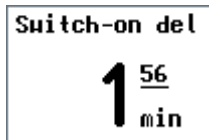

After activating the device with the main switch located on the side, the set switch-on delay starts and runs down to "0".

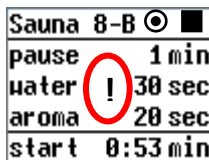

After that, the display switches to the **Start Display**, showing the following information:

- ⇒ Device name as well as signalling of push button contact and operating contact
- ⇒ Set pause time or locking time, respectively
- ⇒ Set time for water dosing
- ⇒ Set time for fragrance, dosing
- ⇒ Time until the start of the next splash or until the end of the locking time, respectively.

Operating contact:

The operating contact is used to switch the device to standby mode via an external signal. In standby mode, only the parameters and test functions can be operated.

The Operating contact function is active in all operation modes and is always displayed.

If the black square is shown in the display, the **operating contact is closed → Normal operation.**

If the white square is shown in the display, the **operating contact is open → Standby mode – no splash.**

Push button contact:

The push button symbol appears in the display when the **Button operation** operation mode is set.

If the **black dot** is shown **in the display**, a signal is pending at the button input or at the input of the 230 V control unit. **A splash occurs.**

If the **white dot** is shown in the display, no signal is pending at the button input or at the input of the 230 V control unit.

6.3.1 Operation modes

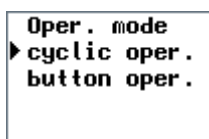

There are 2 operation modes to choose from: **Cyclic operation** and **Button operation**.

Cyclic operation:

The **Cyclic operation** operation mode can be used to specify an individual splash cycle, which is constantly repeated. The water quantity, fragrance quantity and pause time can be set.

Special case:

In **Cyclic operation**, a splash can also be started with the push button. In this case, the pause time starts again from the beginning.

Button operation:

With the **Button operation** operation mode, the pool visitors can determine the time of the splash themselves. The splash is started via a push button in the sauna. The water quantity, fragrance quantity and locking time can be set individually. No splash can be triggered during the locking time.

If the **Button operation** operation mode is selected, the push button symbol / is shown in the display. For this function, the operating contact must be closed.

In **Button operation**, the splash can also be triggered via an external control unit. For this purpose, instead of the push button, the external control unit is connected via a potential-free contact.

6.3.2 Pause time/Locking time

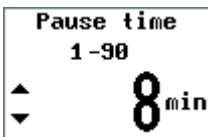

If the **Cyclic operation** operation mode is set, **Pause time** is displayed here. The pause time denotes the time period between splashes. Set the desired pause time between the splashes.

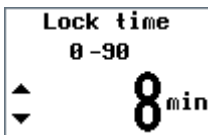

If the **Button operation** operation mode is set, **Locking time** is displayed here. The locking time denotes the time period during which no new splash can be started. Set the desired locking time between the splashes. No further splash is possible during the time period set here.

6.3.3 Water quantity

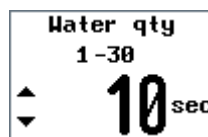

Set the duration of the water splash onto the sauna heater (opening time of the solenoid valve)

6.3.4 Fragrance quantity

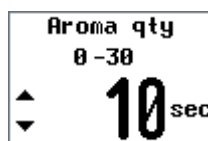

Set the run time of the fragrance dosing pump during the splash. The run time of the fragrance quantity is limited to the set run time of the water quantity. This prevents dosing of the pure fragrance onto the sauna heater.

6.3.5 Switch-on delay

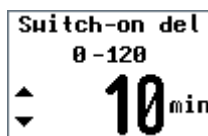

After the voltage is switched on, the first splash will be delayed by the time period set here.

6.3.6 Pump test

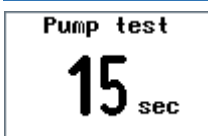

The fragrance dosing pump is activated for the displayed time period. Fragrance is being dosed.

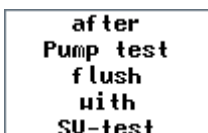

An attempt to start the pump test 2x in a row results in the following message: **"After pump test, rinse with MV test"**. Now activate the MV test in the main menu so that the fragrance is flushed from the line!

6.3.7 MV test

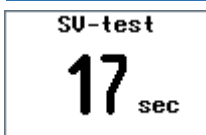

The solenoid valve is activated for the displayed time period. Water is dosed onto the sauna heater.

6.3.8 Pressure test

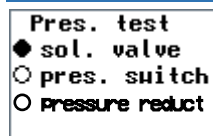

During the pressure test, the solenoid valve is activated and the pressure switch is evaluated. If no fault indication is displayed, the pressure test was successful.



DANGER!

Functioning of the pressure switch is particularly important, so no undiluted fragrance can be dosed onto the sauna heater.

6.3.9 Splash test

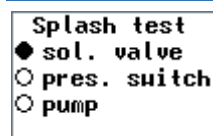

This test is used to check the splash function. A complete splash cycle is run. In turn, the solenoid valve and the pressure switch are queried and the pump is activated. If no fault indication is displayed, the splash test was successful. Otherwise, one of the described fault indications appears.

6.3.10 Contrast

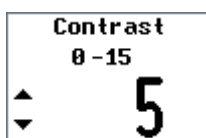

Adjust the contrast for the display

6.3.11 Language

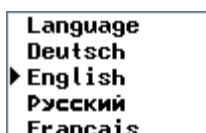

Select the desired language

6.3.12 Info

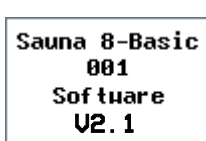

Here, you can find information about the device type and software version.

6.4 Replenish consumables

Fragrance

- Unscrew the cover of the new fragrance delivery container and drill a hole with a diameter of 7 mm in the cover.
- Screw the cover back on and place the delivery container on the console of the automatic sauna splash system.
- Push the suction hose so far into the container that the end of the suction hose comes into contact with the container base and the entire contents can be used.

7 Maintenance, care, faults

7.1 Device maintenance

We recommend that you assign a specialist firm to carry out regular maintenance.

In order to ensure the proper function of the automatic sauna splash system, pay attention to the following points:

1. Regular cleaning of the device
2. Stocking of the consumables
3. Checking and maintenance according to the maintenance protocol in *Chapter 9.5*.



DANGER DUE TO ELECTRICAL VOLTAGE!

Before any electrical work is carried out, the device must be disconnected from the power supply and secured against being reactivated!

7.1.1 Check/change hose kit

The pump hose in the pump is subject to mechanical and chemical stresses. Therefore, the pump hose must be checked every time the fragrance is changed in order to detect damage in due time and to replace the dosing hose.

The dosing hose must be replaced at least every 6 months, and more frequently in the case of aggressive fragrances!

Individual components of the peristaltic pump

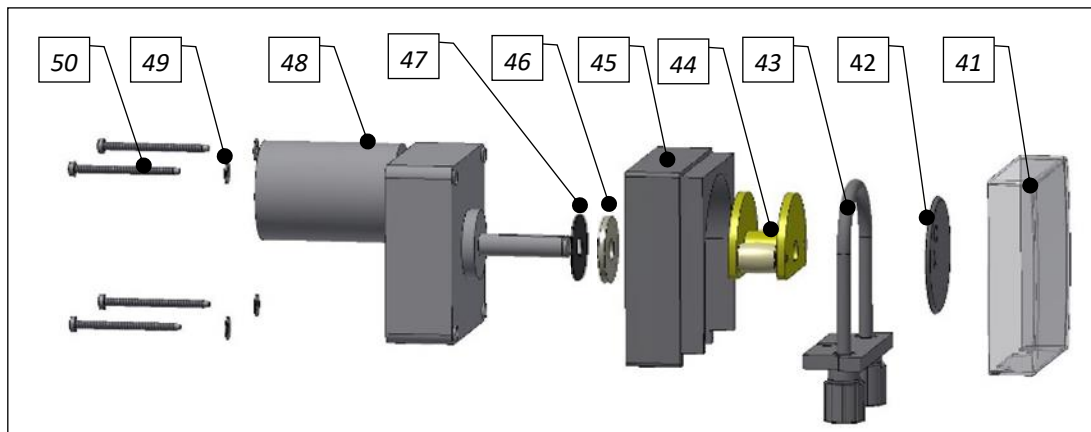

Figure 23, Individual components of the peristaltic pump

Key:

- | | |
|-----------------------------------|-------------------------|
| 41. Transparent protective cover | 46. Sealing washer felt |
| 42. Safety disc | 47. Sealing washer EPDM |
| 43. Hose bracket with dosing hose | 48. Gear motor |
| 44. Roller carrier | 49. Flat washer |
| 45. Pump casing | 50. Screw |

Change hose kit and roller carrier

see description in *Chapter 5.2 Commissioning works, "Insert roller carrier at the fragrance pump"*

Renew hose on hose bracket



ATTENTION!

The new hose must be of the same colour and size as the disassembled hose. The hose must not be twisted when inserted! The markings must be centred at the front (see picture).

1. Remove hose kit, *see Chapter 7.1.1*
2. To replace the dosing hose, **carefully** cut the hose clamps with a sharp knife or pliers! **Never damage the hose nipples!**
3. Push the new dosing hose onto the hose nipples so that the markings on the hose ends are located in the front! This ensures that the hose is not twisted.
4. Attach the hose ends using the hose clamps and cut off the protruding ends of the hose clamps.
5. Install hose kit, *see Chapter 7.1.1*

Individual components of the hose kit

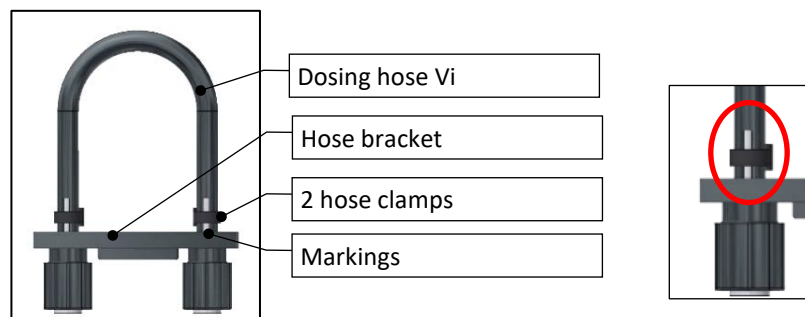

7.1.2 Checking dosing valve

Certain fragrance concentrates cause deposits in the dosing line and in the dosing valve. In this case, water may be pushed back during the splash or the fragrance dosing may stop, especially if the dosing hose is already damaged. Therefore, the dosing valve must be checked every 6 months or as required. When refilling the fragrance, allow some air to be sucked in by the pump and track the air bubble with the fragrance pump running. If the air bubble in the suction-pressure hose is transported further, the fragrance dosing is functioning correctly. If the air bubble only moves back and forth, the dosing valve is blocked. To clean the valve, loosen the dosing hose from the dosing valve, unscrew the dosing valve and wash it out with warm water or rinse it with methylated spirit. If this proves unsuccessful, insert a new valve.

7.1.3 Clean oven shower head

The oven shower head inevitably becomes calcified after a certain period of operation. To clean the oven shower head, switch off the automatic sauna splash system and unscrew the shower head. Clean the shower head mechanically as well as with light acid and screw it back on hand-tight. Only use Teflon tape for sealing.

7.1.4 Clean the dirt filter

Depending on the contamination of the mains water, the dirt filter (Pos 8, page 9) in the inlet must be cleaned. This is required, in particular, shortly after commissioning and after maintenance work, as impurities can easily occur in the pipe and in the water during installation. To do this, close the ball valve (Pos 9), unscrew the filter's sealing plug, pull out the filter element, clean it under running water and reinstall it. Ensure that the seal is not damaged.

7.2 Regular water check

When using drinking water from the piping network, no water check is necessary.

7.3 Fault removal



Tip!

It is also possible that switches or sensors are faulty and thus do not transmit any electrical signals.

Fault indications

The following fault indications may be displayed. For the removal of fault indications, see the following fault table.



Fault indication 1
Water pressure fault



Fault indication 2
Pressure switch fault

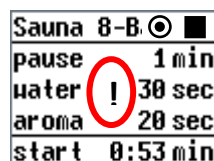

“!” means that a water pressure fault indication occurred within the past 24 h



Fault indication 3
Pressure reduction fault

Fault table

Fault display/fault	possible cause	Actions
Fault indication 1, Water pressure fault; The pressure of 1.2 barg for the splash is not reached, or the pressure drops during the splash. → Safety shut-down of the fragrance pump; <ul style="list-style-type: none"> • The display shows an exclamation mark. • If the required pressure is reached again or the fault has been fixed, fragrance dosing is automatically resumed during the next splash • The exclamation mark only disappears after 24 h of fault-free operation 	<ul style="list-style-type: none"> • Water supply interrupted • Water pressure too low 	<ul style="list-style-type: none"> • Check water supply • Check supply pressure
Fault indication 2, Pressure switch fault; Prior to opening the solenoid valve, the contact of the pressure switch is closed. → further splash blocked	<ul style="list-style-type: none"> • Pressure switch defective • Splash line blocked • Short circuit cable/plug • Manipulation 	<ul style="list-style-type: none"> • Check/renew pressure switch • Check/clean/renew line, check/renew cable/plug.
Fault indication 3, Pressure reduction fault; After closing the solenoid valve, the pressure does not decrease within 3 sec. → further splash blocked	<ul style="list-style-type: none"> • Splash line blocked 	<ul style="list-style-type: none"> • Check/clean/renew the line, decalcify the splash shower head
The device cannot be switched on	<ul style="list-style-type: none"> • Fuse defective • Main switch defective • Power supply interrupted 	<ul style="list-style-type: none"> • Check/renew fuse • Check main switch • Check power supply
Device without function	<ul style="list-style-type: none"> • incorrect setting • Fuse defective • Control board defective • Operating contact open 	<ul style="list-style-type: none"> • Check/reset settings • Renew fuse • Renew circuit board • Close operating contact
Solenoid valve without function	<ul style="list-style-type: none"> • Fuse defective • Solenoid valve/coil defective 	<ul style="list-style-type: none"> • Renew fuse • Check/renew solenoid valve
Dosing pump without function	<ul style="list-style-type: none"> • Fuse defective • Pump motor defective • Pressure switch release missing 	<ul style="list-style-type: none"> • Renew fuse • Check/renew pump motor • Check/renew pressure switch

Button illumination without function	<ul style="list-style-type: none"> • Fuse defective 	<ul style="list-style-type: none"> • Renew fuse
No splash	<ul style="list-style-type: none"> • Fuse defective • Solenoid valve defective • no water supply pressure • Device input filter blocked • Splash line blocked 	<ul style="list-style-type: none"> • Check fuses • Check/renew solenoid valve • Check water supply • Clean input filter • Clean splash line
No fragrance dosing	<ul style="list-style-type: none"> • Fuse defective • Fragrance pump defective • Dosing hose worn • Roller carrier worn • Dosing valve blocked • Insufficient water pressure in the inlet 	<ul style="list-style-type: none"> • Check/renew fuse • Check/renew pump • Renew dosing hose • Renew roller carrier • Check/ clean/renew dosing valve



Tip!

The pressure of 1.2 bar described here refers to the delivery condition of the device. If necessary, WDT may have supplied a pressure switch with a release pressure of 1.0 bar.

Fault indication 1 “Water pressure fault” is cleared automatically as soon as the necessary pressure is reached in the water line during the next splash.

The fault indications 2+3 continue to be permanently shown in the display; the automatic splash system is blocked.

By resetting the fault indication 3, the user is automatically forwarded to the “Pressure switch test” menu, see Chapter 6.3.8.

8 Decommissioning – Storage – Disposal

8.1 General

In the event of decommissioning, the device must be emptied completely or protected against frost!

Disposal of used parts and operating materials

Thoroughly clean any removed, contaminated parts prior to disposal.

Used parts and operating materials must be disposed of according to the regulations applicable at the site of operation, or they must be recycled. If operating materials are subject to special regulations, please pay attention to the corresponding information on the packaging. When in doubt, information may be obtained from the institution responsible for disposal at your location.

If this is not possible, dispose of as hazardous waste.

8.2 Decommissioning

When decommissioning the automatic sauna splash system, switch off the device at the main switch.

For decommissioning of more than 30 days, the fragrance container must be removed from the device.

The fragrance dosing lines must be flushed with water.

For decommissioning, all components must be stored dry and in a cleaned state.

Remove the fragrance pump roller carriers to avoid any damage to the dosing hose. Procedure *see Chapter 5.2*.







ATTENTION!

For recommissioning, it is essential to follow the instructions in the “Commissioning” chapter and to implement the points contained in the commissioning protocol.

9 Documents

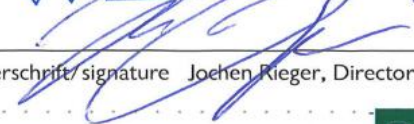
9.1 Declaration of conformity

<p>WDT Werner Dosiertechnik GmbH & Co. KG Hettlinger Straße 17 D-86637 Wertingen Tel. 0049 8272 98697-0 Fax 0049 8272 98697-19 info@werner-dosiertechnik.de www.werner-dosiertechnik.de</p>					
<p>EG-Konformitätserklärung EC declaration of conformity Déclaration de conformité UE</p> <p>im Sinne der EG-Maschinenrichtlinie 2006/42/EG, Anhang II 1.A as defined in the ECMachinery Directive 2006/42 / EC, Annex II, Part 1A selon la directive européenne machines 2006/42 / CE, annexe II 1.A</p>					
<p>Hersteller WDT - Werner Dosiertechnik GmbH & Co. KG Manufacturer Hettlinger Str. 17 Fabricant 86637 Wertingen-Geratshofen</p>					
<p>Beschreibung und Identifikation des Produktes: Description and identification of the product: Description et identification du produit :</p>					
<table border="1" style="width: 100%; border-collapse: collapse;"> <tr> <td style="width: 80%; padding: 5px;">Typenbezeichnung:</td> <td style="width: 20%; padding: 5px;">Art:</td> </tr> <tr> <td style="padding: 5px;">• Saunaaufgussautomatik Typ Sauna Plus 8 und Sauna Plus 8 Basic</td> <td style="padding: 5px;">Maschine</td> </tr> </table>	Typenbezeichnung:	Art:	• Saunaaufgussautomatik Typ Sauna Plus 8 und Sauna Plus 8 Basic	Maschine	
Typenbezeichnung:	Art:				
• Saunaaufgussautomatik Typ Sauna Plus 8 und Sauna Plus 8 Basic	Maschine				
<p>Funktion: Dosiergerät für einen automatischen Saunaaufguss Function: Dosing-system for an automatic sauna-splash Fonction: Système de dosage pour un injection automatique de Sauna</p>					
<p>Es wird ausdrücklich erklärt, dass das Produkt allen einschlägigen Bestimmungen der folgenden EG-Richtlinien entspricht: It is expressly stated that the product complies with all relevant provisions of the following EC directives Il est explicitement dit que le produit est conforme à toutes les dispositions pertinentes des directives CE suivantes :</p>					
<p>2006/42/EG RICHTLINIE 2006/42/EG DES EUROPÄISCHEN PARLAMENTS UND DES RATES vom 17. Mai 2006 über Maschinen und zur Änderung der Richtlinie 95/16/EG (Neufassung) 2014/30/EU RICHTLINIE 2014/30/EU DES EUROPÄISCHEN PARLAMENTS UND DES RATES vom 26. Februar 2014 zur Harmonisierung der Rechtsvorschriften der Mitgliedstaaten über die elektromagnetische Verträglichkeit (Neufassung)</p>					
<p>Die folgenden harmonisierten Normen nach Artikel 7 (2) wurden angewandt: The following harmonized standards as defined in Article 7 (2) were applied: Les normes harmonisées suivantes selon l'article 7 (2) ont été appliquées :</p>					
<p>EN ISO 12100:2010 Sicherheit von Maschinen - Allgemeine Gestaltungsleitsätze - Risikobeurteilung und Risikominderung EN ISO 13849-1:2015 Sicherheit von Maschinen – Sicherheitsbezogene Teile von Steuerungen – Teil 1: Allgemeine Gestaltungsleitsätze EN ISO 13849-2:2012 Sicherheit von Maschinen – Sicherheitsbezogene Teile von Steuerungen – Teil 2: Validierung EN ISO 14120:2015 Sicherheit von Maschinen – Trennende Schutzeinrichtungen Allgemeine Anforderungen an Gestaltung, Bau und Auswahl von feststehenden und beweglich trennenden Schutzeinrichtungen EN 60204-1:2018 Sicherheit von Maschinen – Elektrische Ausrüstung von Maschinen – Teil 1: Allgemeine Anforderungen EN ISO 4413:2010 Fluidtechnik – Allgemeine Regeln und sicherheitstechnische Anforderungen an Hydraulikanlagen und deren Bauteile DIN EN 55014-1:2017 Elektromagnetische Verträglichkeit - Anforderungen an Haushaltgeräte, Elektrowerkzeuge und ähnliche Elektrogeräte - Teil 1: Störaussendung DIN EN 55014-2:2015 Kategorie IV Elektromagnetische Verträglichkeit - Anforderungen an Haushaltgeräte, Elektrowerkzeuge und ähnliche Elektrogeräte - Teil 2: Störfestigkeit - Produktfamiliennorm (CISPR 14-2:2015);</p>					
<p>Die in der Gemeinschaft ansässige Person, die für die Zusammenstellung der technischen Unterlagen bevollmächtigt ist: The designated person who is authorized to draw up the technical documentation: La personne établie dans la communauté qui est autorisée à constituer le dossier technique:</p>					
<p>Name: Werner Dosiertechnik GmbH & Co KG Straße/Nr.: Hettlinger Straße 17 PLZ Stadt: 86637 Wertingen</p>					
<div style="display: flex; justify-content: space-between; align-items: center;"> <div style="width: 40%;"> <p>Wertingen, 14.07.2021</p> <p>Ort/City/Place, Datum/Date</p> </div> <div style="width: 50%; text-align: center;">  <p>Dosiertechnik GmbH & Co.KG 86637 Wertingen-Geratshofen Tel. 0 82 72 98 69 70 Fax 9 86 97-19</p>  <p>Unterschrift/signature Jochem Rieger, Director</p> </div> </div>					
					
<p>CE DW 001-01 Konformitätserklärung Sauna Plus 8+Basic.docx</p>					

9.2 Wiring Diagram

Notice for wiring diagrams: The wiring diagrams can also be found near the device's control cabinet.

Wiring diagram cyclic operation/button operation

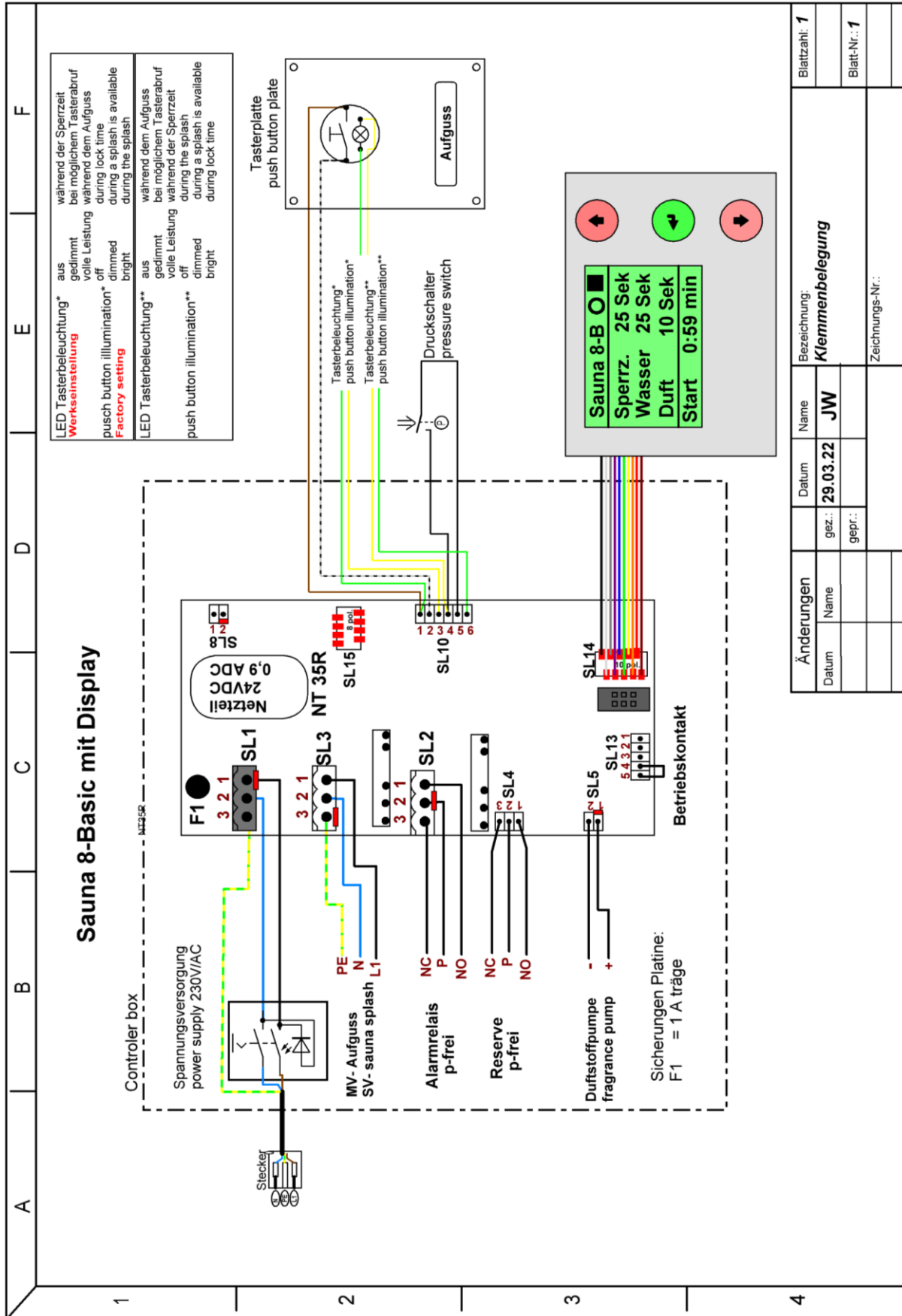

9.3 Commissioning protocol / instruction

This protocol is to be completed by the commissioning technician! Without a completed and signed commissioning protocol, all warranty claims become void!

The commissioning protocol is located in the accompanying documentation.

**Tip!**

During commissioning, enter the operating parameters in the operation data sheet!

Menu	Factory setting	Setting ranges	Step	during commissioning	Optimised during operation
				Date:	Date:
Pause time (for cyclic operation) Locking time (for button operation)	15 minutes	1-90 minutes	1		
Water quantity	15 seconds	1-30 seconds	1		
Fragrance quantity	10 seconds	0-30 seconds			
Operation mode	Cyclic operation	Cyclic operation Button operation			
Switch-on delay	30 minutes	0-120 minutes	1		
Pump test		Sequence programme			
MV test		Sequence programme			
Pressure test		Sequence programme			
Splash test		Sequence programme			
Contrast	10	0-15	1		

Operation data sheet

Menu	Factory setting	Setting ranges	Step	during commissioning	Optimised during operation
				Date:	Date:
Pause time (for cyclic operation) Locking time (for button operation)	15 minutes	1-90 minutes	1		
Water quantity	15 seconds	1-30 seconds	1		
Fragrance quantity	10 seconds	0-30 seconds			
Operation mode	Cyclic operation	Cyclic operation Button operation			
Switch-on delay	30 minutes	0-120 minutes	1		
Pump test		Sequence programme			
MV test		Sequence programme			
Pressure test		Sequence programme			
Splash test		Sequence programme			
Contrast	10	0-15	1		

Operation data sheet, --master copy--

Menu	Factory setting	Setting ranges	Step	during commissioning	Optimised during operation
				Date:	Date:
Pause time (for cyclic operation) Locking time (for button operation)	15 minutes	1-90 minutes	1		
Water quantity	15 seconds	1-30 seconds	1		
Fragrance quantity	10 seconds	0-30 seconds			
Operation mode	Cyclic operation	Cyclic operation Button operation			
Switch-on delay	30 minutes	0-120 minutes	1		
Pump test		Sequence programme			
MV test		Sequence programme			
Pressure test		Sequence programme			
Splash test		Sequence programme			
Contrast	10	0-15	1		

Operation data sheet --

Menu	Factory setting	Setting ranges	Step	during commissioning	Optimised during operation
				Date:	Date:
Pause time (for cyclic operation) Locking time (for button operation)	15 minutes	1-90 minutes	1		
Water quantity	15 seconds	1-30 seconds	1		
Fragrance quantity	10 seconds	0-30 seconds			
Operation mode	Cyclic operation	Cyclic operation Button operation			
Switch-on delay	30 minutes	0-120 minutes	1		
Pump test		Sequence programme			
MV test		Sequence programme			
Pressure test		Sequence programme			
Splash test		Sequence programme			
Contrast	10	0-15	1		

9.5 Maintenance protocol

Carry out the specified maintenance tasks in order to protect any warranty claims.
The maintenance protocol is located in the accompanying documentation.

9.6 Spare parts list, wear parts list, list of consumables

**Tip!**

Do you need spare parts, wear parts or consumables? You are welcome to order these from your service partner or your specialist dealer.

Spare parts list

<u>Device</u>	<u>Position</u>	<u>Designation</u>	<u>Article no. WDT</u>
Fragrance pump	31	Cover for pump casing Sa, transparent	14259
	32	Safety disc for roller carrier Sa	13633
	33	Hose bracket with hose SA-3.2 Vi	13358
	--	Hose kit SA 3.2x1.6 Vi - 2x	12782
	34	Roller carrier for peristaltic pump	12609
	35	Pump casing Sa	14140
	36	Sealing washer felt Sa	14166
	37	Sealing washer EPDM Sa	12709
	38	Gear motor Sa 24 VDC	13557
	39	Mounting screws, set	17067
Water supply part	09	Ball valve Ms ½"	18895
	08	Inclined angle filter Ms ½"	11479
	03	Pipe aerator 1/ 2" with RV	19877
	04	Solenoid valve VA ¼" NC 230 VAC	29152
	--	Solenoid valve plug with LED and cable	13082
	14	Suction hose PE 4x1 - 1 m	12064
	05	Pressure switch ½"	11335-1
	--	Protective cap for pressure switch Ms ½"	11337
	--	Dosing pipe	16865
	--	Dosing valve angled shape for fragrance 3/8" VA sauna	25959
	--	Dosing line PTFE di 4x1 mm, 0.5 m	10432
	--	Oven shower head	15211
	--	Wall bushing	15214
Control unit	--	Fuse bag 2x2 A, 8.3x8	25976
	--	Fuse bag 2x315 mA Tr 8.3x8	23625
	02	Control housing complete	25979
	--	Control board NT 35-R	28231
	--	Display HMI MP3	27553
	--	Mains switch	21468

Wear parts list

<u>Device</u>		<u>Designation</u>	<u>Article no. WDT</u>
	--	Hose kit SA 3.2x1.6 Vi – 2x	12782
	--	Roller carrier for peristaltic pump	12609

List of consumables

Fragrances: A list of current fragrances can be obtained from WDT.

10 Appendices

- Commissioning protocol
- Maintenance protocol

Personal notes

Commissioning Protocol IP-004-EN

Sauna Plus 8 and Sauna Plus 8 Basic



This protocol is to be completed by the commissioning technician! Without a completed and signed commissioning protocol, all warranty claims become void!

Object: _____ Date: __/__/__

City, street, house number: _____

Device type: _____ Year of manufacture: _____ Serial number: _____

	Activity	Completed	Comment
1	<u>Commissioning</u>		
1.1	Roller carrier inserted	<input type="checkbox"/>	
1.2	Device checked for correct installation	<input type="checkbox"/>	
1.3	Water inlet flushed, checked and opened	<input type="checkbox"/>	
1.4	Device and lines checked for leaks	<input type="checkbox"/>	
1.5	Does the splash line run completely empty? <ul style="list-style-type: none"> • Yes, → Optional system separation unit not required • No, → Optional system separation unit required and installed • No, → Optional system separation unit required but not installed 	<input type="checkbox"/> <input type="checkbox"/> <input type="checkbox"/>	no operation permitted, according to DIN EN 1717!
1.6	Fragrance container connected	<input type="checkbox"/>	
1.7	All test programmes checked	<input type="checkbox"/>	
1.8	Settings made and operation mode selected	<input type="checkbox"/>	
1.9	Flow pressure of supply water line checked Attention! Other consumers in the vicinity of the automatic splash system may influence the flow pressure! bar	
1.10	Automatic sauna splash system started	<input type="checkbox"/>	
1.11	Device checked for correct operation	<input type="checkbox"/>	
1.12	Water and fragrance quantities adjusted to cabin size (manufacturer's instructions for fragrance quantity observed!)	<input type="checkbox"/>	
2	<u>Other</u>		
2.1	Operating instructions reviewed and handed over	<input type="checkbox"/>	
2.2	Service and operating personnel instructed	<input type="checkbox"/>	

Additional remarks:

Commissioning and instruction carried out by: _____

Instructed persons: _____

Signature of commissioner: _____

Countersigned by operator: _____

Maintenance protocol WP-011-EN

Sauna Plus 8 and Sauna Plus 8 Basic



This protocol must be completed by the maintenance technician! We reserve the right to determine the warranty conditions when no completed and signed maintenance protocol is available.

Object: Year of maintenance: 20__

City, Street, Street number:

Device type: Year of construction: Serial no.:

	Activity	Maintenance interval in	Month 1	Month 2	Month 3	Month 4	Month 5	Month 6	Month 7	Month 8	Month 9	Month 10	Month 11	Month 12	Comment / additional work
1	Sauna Plus 8 and Sauna Plus 8 Basic														
1.1	Check hose pump(s) for function and leak-tightness	1	<input type="checkbox"/>	<input type="checkbox"/>	<input type="checkbox"/>	<input type="checkbox"/>	<input type="checkbox"/>	<input type="checkbox"/>	<input type="checkbox"/>	<input type="checkbox"/>	<input type="checkbox"/>	<input type="checkbox"/>	<input type="checkbox"/>	<input type="checkbox"/>	
1.2	Check the device for leak-tightness	3			<input type="checkbox"/>			<input type="checkbox"/>			<input type="checkbox"/>			<input type="checkbox"/>	
1.3	Perform test programmes	3			<input type="checkbox"/>			<input type="checkbox"/>			<input type="checkbox"/>			<input type="checkbox"/>	
1.4	Operate fittings, check for function and leak-tightness	3			<input type="checkbox"/>			<input type="checkbox"/>			<input type="checkbox"/>			<input type="checkbox"/>	
1.5	Exchange hose set (only use WDT original part)	6						<input type="checkbox"/>						<input type="checkbox"/>	
1.6	Clean the device	6						<input type="checkbox"/>						<input type="checkbox"/>	
1.7	Check and clean dosing valve(s)	6						<input type="checkbox"/>						<input type="checkbox"/>	
1.8	Clean the heater shower	6						<input type="checkbox"/>						<input type="checkbox"/>	
1.9	Clean the dirt filter	12												<input type="checkbox"/>	
1.10	Check electrical cabling	12												<input type="checkbox"/>	

Other comments:

Maintenance performed by: Date:

Countersigned by operator:

